

**SECTION 23 09 93**  
**SEQUENCE OF OPERATIONS FOR HVAC CONTROLS**

**PART 1 - GENERAL**

**1.01 SUMMARY**

- A. This section describes the sequence of operations for HVAC control systems specified elsewhere in these specifications.
- B. Related Work: The requirements of Section 23 05 00, Common HVAC Materials and Methods, also apply to this section.

**PART 2 - PRODUCTS**

**2.01 NO PRODUCTS LISTED FOR THIS SECTION**

**PART 3 - EXECUTION**

**3.01 SEQUENCE OF OPERATIONS**

- A. Provide a complete and operational temperature control and building automation system based on the following points and sequence of operation, complete as to sequences and standard control practices. The determined point list is the minimum amount of points that are to be provided. Provide any additional points required to meet the sequence of operation.
- B. Object List:
  - 1. The following points as defined for each piece of equipment are designated as follows:
    - a. Binary Out (BO) - Defined as any two-state output (start/stop) (enable/disable), etc.
    - b. Binary In (BI) - Defined as any two-state input (alarm, status), etc.
    - c. Analog In (AI) - Defined as any variable input (temperature) (position), etc.
    - d. Analog Out (AO) - Defined as any electrical variable output. 0–20mA, 4–20mA and 0–10VDC are the only acceptable analog outputs. The driver for analog outputs must come from both hardware and software resident in the controllers. Transducers will not be acceptable under any circumstance.
- C. Occupancy and Performance Time Periods:
  - 1. Occupied Period is signaled automatically by adjustable settings at DDC server, Building Controller, Application Controller and also, at each zone when zone bypass timer is activated.
  - 2. Warm-up period occurs one hour before occupied start time or as calculated by Building Controller based on system performance history and outside air temperature.
  - 3. Unoccupied period occurs whenever Occupied, Warm-up, or Cool-down are not in effect.

**PART 4 - SEQUENCE OF OPERATION**

**4.01 LEVEL OF DETAIL**

- A. Major changes in provided sequence of operation must be approved of in writing by the owner and the Engineer.

- B. The Control Contractor shall provide two types of documentation for each system (e.g., boiler plant, VAV system, etc.). The two types of documentation include:
1. Control Logic
    - a. Control logic shall be a series of statements providing, for each system, the following items:
      - 1) Identification of control process
      - 2) Narrative of control loop or logic algorithm
      - 3) Control parameters such as setpoints and differentials (e.g., throttling range, gains) reset schedules, and adjustable parameters for all points
      - 4) Identification of all constraints, limits, or interlocks that apply to control loop
      - 5) Identification of all DO, DI, AO, AI points that apply to system
      - 6) Identification of all communication needs (data points from outside control unit)
  2. Logic Diagrams
    - a. For each control logic system, a logic diagram shall show the actual interaction of the points (real and virtual) and the logic algorithm.
    - b. The diagram should identify
      - 1) System being controlled (attach abbreviated control logic text)
      - 2) All DO, DI, AO, AI points
      - 3) Virtual points
      - 4) All functions (logic, math, and control) within control loop
      - 5) Legend for graphical icons or symbols
      - 6) Definition of variables or point names (e.g., OAT = outside air temperature)
      - 7) Define values (e.g., 1 = on, 0 = off)
    - c. See figure below for example of logic diagram).

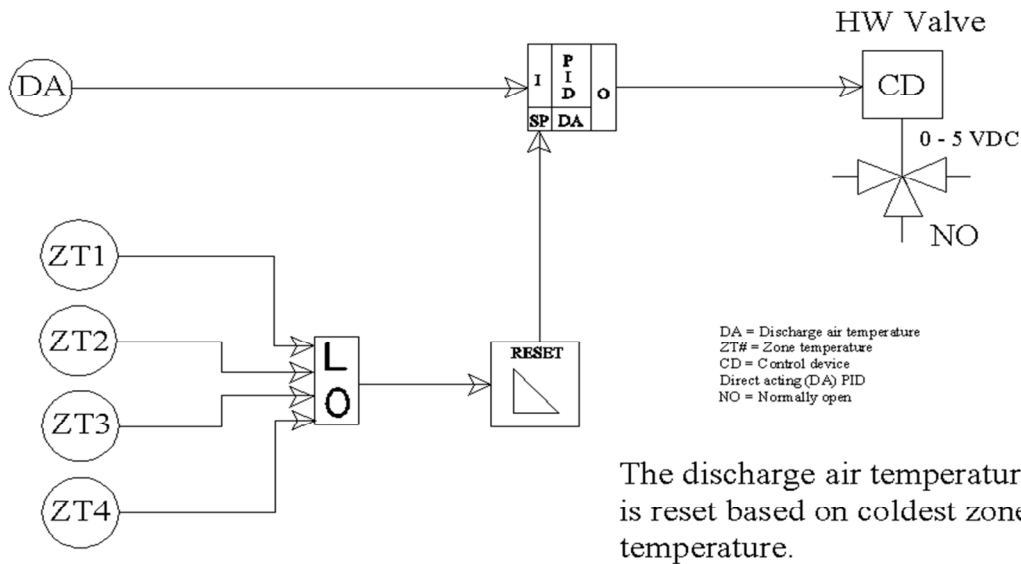

#### 4.02 STANDARDIZATION

- A. All control loops will be standardized throughout the programming code.

#### **4.03 PROGRAMMING GUIDELINES**

- A. All adjustable setpoints shall be developed as software points stored at memory locations so that setpoints can be changed by recommending the data stored at the memory location rather than by entering the program and changing parameters and lines in program code.
- B. Where reset schedules are specified or required the schedules shall be set up so that the operator enters the following points into memory locations.
  - 1. Two points for the independent variable on the reset schedule.
  - 2. Two points for the dependent variable on the reset schedule.

The computer system shall then use these values as input parameters to the appropriate program or programs and calculate the reset schedule based on these values.

- C. Where several analog outputs are to be controlled in sequence by one control loop, software shall be arranged so that the sequence is guaranteed regardless of the spring range of the actuators and to prevent simultaneous heating and cooling.
- D. Programs controlling several pieces of equipment as one system shall reside in one control unit. Where programs use data points that reside in other control units the programs shall employ logic (either in software, firmware, hardware, or a combination of all three) to detect loss of communications with the remote control units containing the required data. When such a failure is detected, the program logic shall revert to a safe operating mode that will allow the controlled systems to remain in operation until normal system communication resumes. A pilot light on the control unit shall be illuminated when such a failure mode exists. In addition, an alarm shall be sent to the HOST computers (alarm level 4). The software shall track this type of alarm and report if communication failure is higher than expected (this condition shall generate an alarm level 3, with descriptive text, at the HOST computer). All safe operating modes shall be approved by the Engineer prior to implementation.
- E. Control sequences that use outdoor air conditions to trigger certain specific operating modes shall use data generated by one outdoor air temperature sensor and one outdoor humidity sensor. In other words, the data from one pair of sensors shall be shared by the entire system.
- F. All safety circuits shall be hard wired circuits using standard snap acting electric or pneumatic switches as required by the function, and shall be totally independent of the DDC system controllers. This includes interlocks that return dampers and valves to some normal, fail-safe position when the system they are associated with shuts down. It is the intent of this paragraph that the systems have the capability to be operated manually complete with safeties and fail safe interlocks even if the DDC system is off line.
- G. Provide hours of operation accumulation and lead/lag sequencing of equipment based on hours of operation for all equipment with proof of operation inputs.
- H. Global point name changing:
  - 1. The system shall provide an easy means to allow the operator to change a point name such that the point will automatically be referenced everywhere in the system by the new name.
  - 2. If a point name is removed from the database, any program code where the name appears must show an appropriate error signal for undefined point when the program is viewed, edited, or printed.
- I. Synchronization of real-time clocks between all control panels shall be provided.

#### **4.04 GENERAL SEQUENCE OF OPERATION GUIDELINES**

- A. Control of all central fan systems, boilers, DX units, heaters, and pumping stations shall be based on run requests, heating requests or cooling requests from zone controls.
- B. Reset of supply air temperature and hot water temperature shall be based on zone temperature conditions via the zone's percentage of heating or cooling load.
- C. Unless otherwise indicated, all control loops will use PID loops. The coefficient for the derivative component is zero (0) unless otherwise indicated.
- D. All HVAC system controls shall be designed such that simultaneous heating and cooling, reheating, and recooling are minimized. This applies as well to non-mechanical treatment of mixed air (e.g. outside air, heat recovery, etc.) which must then be mechanically reheated or re-cooled.
- E. Alarms: Except as directed otherwise by the Owner, all alarms will be registered at the building operator's terminal as well as at the Maintenance Building remote operator's station. Alarms are to be registered with a message explaining the nature of the alarm and which building/location the alarm is in.
- F. Whenever a setpoint is referred to as "adjustable" in these standards, the setpoint is to be easily and directly adjustable at the operator's terminal and Maintenance Building remote operator's station, and is not to require any code modification. This may require assigning virtual points to all adjustable setpoints. Frequently adjusted points, including space temperature setpoints, shall be adjustable from the graphics screen (e.g., floor plan screen).
- G. There are many interlocks and limits within each control loop or algorithm that may not be obvious or stated in this specification. The Control Contractor is responsible for identifying and programming these interlocks and limits into the software. The CO<sub>2</sub> Demand Ventilation Control algorithm is a good example of the complexity of the control loop with interlocks and limits.
- H. The Control Contractor will replace any and all equipment (actuators, chillers, etc) that fail due to programming errors. Such errors include, but are not limited to: moving actuators a couple fractions of a degree every second or so in response to some infinitesimal change in a measured variable or repeatedly turning equipment on/off within a short time period. The Control Contractor will avoid these problems by incorporating time delays, dead bands, and other programming techniques into the sequence of operation.
- I. Programmable time-of-day (start/stop) control shall be implemented for all HVAC equipment, except for:
  - 1. Equipment that is interlocked with other equipment under direct start/stop control (e.g. exhaust fans interlocked with an air handling unit).
  - 2. Equipment that must run continuously for reasons of safety
  - 3. As otherwise noted in these standards.
- J. Auto-tuning algorithms shall not be used to initially tune control loops.

#### **4.05 SEQUENCE OF OPERATION GUIDELINES**

- A. This specification is intended to refine or elaborate on the sequence of operations provided by the Engineer. Note: there are many issues that may make any of these standard sequences inapplicable to a specific situation: thus, the Control Contractor should obtain written approval by the Engineer to implement the sequence of operations contained in this specification.

- B. The Control Contractor shall adhere to all applicable specifications, unless they submit written exceptions to the Owner and Engineer and such exceptions are approved in writing. Written exceptions shall state the specification's sequence of operations, the Control Contractor's proposed sequence of operations, and the reasons why the proposed sequence specifications are preferable to the sequences in this specification or those provided by the Engineer.
- C. It is the Control Contractor's responsibility to improve upon these specified sequences of operations if necessary. All improvements will be provided in writing to the Engineer for his/her written approval.
- D. The Control Contractor is responsible for accurately controlling and communicating with all packaged fan units or air handling units.

#### **4.06 SEQUENCE OF OPERATION**

- A. Supply Fan Control:
  - 1. This section applies to supply fans that are modulated by variable frequency drives (VFDs).
  - 2. Static Pressure Control:
    - a. Supply fan volume is controlled to maintain the duct static pressure at setpoint as sensed at remote static pressure sensor.
    - b. Ensure that the static pressure signal is communicated quickly to the control loop (and not delayed due to network timing) and that a default value is set in the event of a network failure.
    - c. Control duct pressure at AHU:
      - 1) Initiate start fan command before signal sent to VFD
      - 2) Run timer should limit initial start up to 50% full power (ramp up without overshooting)
      - 3) Ramp-up and ramp-down incremental changes shall be equal.
      - 4) Use P or PI loop to control fans speed based on static pressure setpoint.
    - d. Pressure Reset Control: On any (2) (adjustable) VAV box dampers at 100% (adj.) open reset discharge static pressure up by 0.010" (adj.) WC every 5 minutes. On all VAV dampers at 95% (adj.) open or less reset discharge pressure down by 0.05" (adj.) WC every 5 minutes.
  - 3. Variable speed drive acceleration settings, deceleration settings, minimum speeds, etc. shall be adjusted at start up in coordination with the drive supplier and installer to achieve stable control system performance.
  - 4. Fan speed is reset to 0 (zero) Hz when the AHU is off.
  - 5. Coordinate signal from fire alarm panel to duct mounted smoke detector. One signal to detector disables fan (Hz = 0), waits 15 seconds (adjustable), and starts smoke damper closing.
  - 6. Duct High Pressure Shutdown: When the duct pressure exceeds the high limit set point (4" in H<sub>2</sub>O, adjustable at the device) the fan will shut down for three (3) minutes (adjustable) and then attempt to restart. If three (3) restart attempts occur over a period of 15 minutes (adjustable), the system shall be disabled (software). Lockout reset will occur at the operator's workstation.
- B. Return Fan Control:
  - 1. This section applies to return fans with variable frequency drives (VFDs).
  - 2. Fan will start/stop when supply fan starts.
  - 3. Space pressure Control, Return Fan Speed Endpoints: The return fan shall modulate based on supply fan speed and outside air damper position. The air balancing contractor will attain the return fan speed based on the following values for the given operating mode.

Return Fan Speed Endpoint Values				
Mode	Supply Fan Speed Hi/Lo Reset Limits	Desired Space Pressure (InH2O)	Economizer Position	Return Fan Speed
Full Heating (All terminal units are operating at heating flow setpoints)	TBD – Noted during the full heating condition	<b>Ideal - 0.02</b> Acceptable Test Range: 0.01 – 0.03	Min-Min (25% of the minimum ventilation requirement)	Minimum Return Fan Speed-TBD
Full Cooling (All terminal units are operating at cooling flow setpoints)	TBD – Noted during the full cooling condition	<b>Ideal - 0.02</b> Acceptable Test Range: 0.01 – 0.03	Min-Max (100% of the minimum ventilation requirement)	Maximum Return Fan Speed-TBD

4. Space Pressure Return Fan Speed Reset: During Occupied mode the return fan speed shall reset based on the following schedule.

Return Fan Speed Reset Schedule	
Supply Fan Speed	Return Fan Speed
Supply Fan Speed Lo Reset Limit-TBD	Minimum Return Fan Speed-TBD
Supply Fan Speed Hi Reset Limit-TBD	Maximum Return Fan Speed-TBD

5. During warm-up and night low limit, operate the unit in 100% recirculation mode.  
6. Fan speed is reset to zero (0) Hz when the AHU is off.  
7. Variable speed drive acceleration settings, deceleration settings, minimum speeds, etc. shall be adjusted at start up in coordination with the drive supplier and installer to achieve stable control system performance.  
8. Provide separate sequences to be enable if directed by engineer to control fan based on a set difference in fan speed between supply air and return air, using this method rather than space pressure control.

C. Discharge Air Temperature Reset:

1. Occupied Mode: The discharge air setpoint will reset based on the maximum cooling demand from the spaces. When the maximum cooling demand of any two (2) (adjustable) terminal units is greater than 95%, the discharge air setpoint shall reset down by 0.5 °F (adjustable) every five (5) minutes (adjustable). When the maximum cooling demand is less than 90%, reset discharge air setpoint up by 0.5 °F (adjustable) every five (5) minutes (adjustable). Minimum and maximum discharge air set points are 55 °F (adjustable) and 65 °F (adjustable) respectively. Initial discharge air temperature setpoint when transitioning into an occupied mode is based on the following schedule.

Initial Discharge Air Setpoint	
Maximum Terminal Unit Cooling Demand	Discharge Air Temperature Setpoint
0	65
100	55

2. The following discharge air setpoints are applicable for all other modes:

<b>Discharge Air Setpoints, Non-Occupied Modes</b>	
<b>Mode</b>	<b>Discharge Air Temperature Setpoint (adjustable)</b>
Night High Limit	50
Nigh Low Limit	85
Cooling Optimal Start	50
Heating Optimal Start	85
Night Purge	50

- D. Fan Enable / Optimal Start Control or Warm-Up Mode:
  1. All fan systems with heating capability (in AHU and/or at terminal units) shall have this sequence.
  2. The intent of this sequence is that the air handling system be started early enough so that the maximum negative deviation of space temperature from the occupied heating set point (for all within the system) is less than 0.5 °F no more than 20 minutes prior to or 10 minutes after scheduled occupancy. Spaces should not be heated up above occupied heating space temperature set points.
  3. Air handling systems may be started under the optimal start mode no more than 3 hours (adjustable) prior to scheduled occupancy.
  4. This optimal start sequence will be locked out when the 3 hour rolling average outdoor air temperature is greater than setpoint (initial setpoint, 55°F, adjustable). If locked out, the AHU will start 10 minutes (adjustable, maximum of 30 minutes) before occupied time period.
  5. Air handling systems will be started as a function of:
    - a. Outdoor air temperature
    - b. Space temperature
    - c. Time until start of scheduled occupancy
    - d. Historical time period required to reach setpoint as a function of a, b, and c above.
  6. Discharge air temperature setpoint will be set to the maximum optimal start temperature setpoint (85°F, adjustable) during this mode. (100°F for AHU-1)
  7. When the system is in heating optimal start mode, the mixed air dampers will be in full recirculation mode (i.e., outside air dampers are fully closed and the supply air volume will be limited to the return volume).
  8. Unit is operating at full cooling air flow rate.
  9. Exhaust fans are off and exhaust dampers are closed.
  10. Mechanical cooling is disabled.
  11. The building operator will be able to command start of occupancy at the operator's terminal and at the Maintenance Building remote operator's station (overriding the optimal start sequence) for each individual air handling system and globally for all air handling systems in the building.
  
- E. Fan Enable / Optimal Start Control (Cooling Mode) – Cool Down:
  1. All air handling systems with cooling capability shall have this sequence.

2. The intent of this sequence is that the air handling system be started early enough so that the maximum positive deviation from the space temperature to the occupied cooling set point (for all zones in the system) is less than 0.5 °F no more than 20 minutes prior to or 10 minutes after scheduled occupancy. Spaces should not be cooled down below occupied cooling space temperature set points.
3. Air handling systems may be started under the optimal start mode no more than 3 hours (adjustable) prior to scheduled occupancy.
4. This optimal start sequence should be locked out when the 3 hour rolling average outdoor air temperature during the scheduled unoccupied mode is less than setpoint (initial setpoint, 50°F, adjustable). If locked out, the AHU will start 10 minutes (adjustable, maximum of 30 minutes) before the occupied time period.
5. Air handling systems will be started as a function of:
  - a. Outdoor air temperature
  - b. Space temperature
  - c. Time until start of scheduled occupancy
  - d. Historical time period required to reach setpoint as a function of a, b, and c above.
6. Discharge air temperature setpoint will be set to the minimum temperature setpoint during this mode.
7. Mechanical cooling is disabled unless spaces have not achieved cool down setpoint (adjustable) 30 minutes (adjustable) before the occupancy period. Mechanical cooling will utilize economizer mode if outside air temperature is less than return air temperature.
8. Exhaust fans are on and exhaust dampers are open (unless limited by mixed air setpoint control due to outside air damper interlock).
9. Heating is disabled.
10. The building operator will be able to command start of occupancy for each individual air handling system and globally for all air handling systems in the building.

F. Compressor Operation (Cooling Mode):

1. Cooling section shall modulate in sequence with economizer dampers to maintain discharge air temperature setpoint. Discharge air control is applicable whenever mechanical cooling is required.
2. Mechanical cooling shall remain off during warm-up and night low limit.
3. Compressor Staging (Increased Cooling Demand): When mechanical cooling is enabled the first stage compressor demand shall modulate to maintain discharge air temperature setpoint. When the first stage compressor demand maintains 100% for 5 minutes enable the second stage compressor and reduce the first stage compressor demand to 10% (adjustable) then continue to modulate the first stage compressor to maintain the discharge air set point. If system cooling demand continues to increase and the first stage compressor demand maintains 100% for 5 minutes, enable the third stage compressor and reduce the first stage compressor demand to 10% (adjustable) then continue to modulate the first stage compressor to maintain the discharge air set point. Staging on increased cooling demand should continue in this fashion based on the number of cooling stages available.
4. Compressor Staging (Decreased Cooling Demand): When mechanical cooling is enabled and the first stage compressor demand is reduced to less than 10% (adjustable) for 5 minutes, disable the first stage compressor. As cooling demand continues to decrease disable the last full capacity compressor (if applicable) and enable the first stage compressor at 75% (adjustable) demand then modulate demand to maintain discharge air temperature setpoint. Staging on decreased cooling demand should continue in this fashion based on the number of cooling stages available.
5. Mechanical Cooling shall not operate when outside air temperature is below 60 °F (adjustable).
6. Cycle time of any compressor to be a minimum of 10 minutes (adjustable).



7. Suction Pressure Demand Limiting: Suction pressure demand limiting has priority over discharge air temperature cooling demand. If suction pressures migrate outside of normal operating limits, compressor staging is limited and reduced to maintain acceptable limits. Compressors should be staged off and controlled in the same fashion as the decreased cooling demand sequence. Acceptable suction pressure operating limits should be coordinated with the unit manufacture and verified with start-up data.
- G. Heating Mode:
1. Discharge air control is applicable whenever mechanical heating is required. During occupied mode, mechanical heating is permitted when the economizer has maintained the minimum outside air position for a minimum of 5 minutes (adjustable) when ventilation demand sequences are inactive or when ventilation demand sequences are active and the discharge air temperature is more than 3°F below the setpoint for more than 5 minutes (adjustable).
  2. Mechanical heating permitted only during occupied, night low limit and heating optimal start modes.
  3. When mechanical heating is enabled hot water heating valve shall modulate to maintain discharge air temperature setpoint.
  4. Mechanical heating permitted to operate at any outside air temperature, limited by suction pressure.
- H. Night Low Limit Mode:
1. Night low limit mode is initiated during unoccupied times (mode), when any two (2, adjustable) terminal unit space temperature(s) falls below the unoccupied heating setpoint.
  2. When all spaces served by the system are above the unoccupied heating setpoint plus the dead band setpoint (initial 5°F, adjustable), the system will revert to the unoccupied mode.
  3. If the minimum hourly outside air temperature is less than 20°F (adjustable) in Western Oregon for the previous 12 (adjustable) consecutive hours, then the AHU will remain in operation during the unoccupied period. The system will maintain a setpoint temperature 10°F (adjustable) less than occupied setpoint. All outside air dampers will remain closed during the unoccupied period.
- I. Night High Limit Mode:
1. Night high limit mode is initiated during unoccupied times (mode), when any two (2, adjustable) terminal unit space temperature(s) rises above the unoccupied cooling setpoint and the outside air temperature is 10°F (adjustable) less than the average space temperature.
  2. When all spaces served by the system are below the unoccupied heating setpoint minus the dead band setpoint (initial 5°F, adjustable), the system will revert to the unoccupied mode.
- J. Night Purge Mode:
1. This sequence is initiated before occupancy during the cooling season.
  2. Night purge will be enabled when the following conditions are true:
    - a. The average space temperature is above 80° F (adjustable).
    - b. Outside air temperature is greater than setpoint (initial setpoint, 45°F, adjustable).
    - c. Outside air relative humidity is less than 50%.
    - d. Outside air temperature is at least 10°F (adjustable) less than the average space temperature
    - e. Occupancy period occurs within 3 hours (adjustable).
  3. Night purge will be disabled when average space temperature is within 3°F (adjustable) of the outside air temperature or the average space temperature has reach the occupied heating set point.

- K. Economizer Damper Control:
1. Occupied Mode: Economizer dampers (Outside Air, Return Air and Relief Air) modulate to maintain supply air temperature set point and air quality setpoint.
  2. Economizer shall operate as first stage of cooling. If discharge set-point is not satisfied for 5 minutes (above set-point) enable cooling.
  3. Unoccupied, Night Low Limit, Optimal Start and Low Limit Freeze Conditions: Dampers to modulate to full recirculation (0% Outside Air).
  4. Night High Limit and Night Purge: Dampers to modulate to full ventilation (100% Outside Air).
  5. The outside air economizer is enabled when the outside air enthalpy is less than the return air enthalpy.
  6. The outside air economizer is disabled when the outside air enthalpy is greater than the return enthalpy for greater than 2 minutes. When the economizer is disabled, the outside air damper modulates to the minimum position setpoint based on the air quality sensor.
  7. Demand Ventilation Control (DVC): During occupied mode the outside air dampers shall modulate to maintain supply air CO<sub>2</sub> levels at level listed on drawings (adjustable). DVC shall occur when levels begin to exceed the CO<sub>2</sub> set point, or when VAV zones send a signal that zone is in high CO<sub>2</sub> condition.
  8. Economizer Minimum Position (Air Quality Control): Economizer minimum-minimum (min-min) position value is based on 25% of the minimum ventilation requirement unless otherwise noted. Damper position is set based on CO<sub>2</sub> set point value at supply air. The economizer minimum-maximum (min-max) position is based on the full minimum ventilation requirement. During DVC sequences, outside air damper position (outside airflow) is limited to the min-max setting. Balancer to determine actual damper positions at the min-min and min-max airflow setpoints. Control system shall use damper position setpoints for control purposes and use airflow rate as feedback to verify proper economizer damper operation.

**4.07 SEQUENCE OF OPERATION – TERMINAL UNIT CONTROL**

- A. Terminal Unit Control:
1. Space Temperature Setpoints:  
Default Setpoints:
    - a. Occupied Heating Setpoint: 70 °F (adjustable)
    - b. Occupied Cooling Setpoint: 76 °F (adjustable)
    - c. Unoccupied Heating Setpoint: 55 °F (adjustable)
    - d. Unoccupied Cooling Setpoint: 85 °F (adjustable)
    - e. Standby Occupied Heating Setpoint: (Occupied Heating Setpoint - 3°F (adjustable))
    - f. Standby Occupied Cooling Setpoint: (Occupied Cooling Setpoint + 3°F (adjustable))
  2. Space Setpoint Adjustment:
    - a. Adjustment (General): Setpoint adjustments may be accomplished either at the operator workstation or locally at the thermostat.
    - b. Adjustment Range: Setpoint adjustments are limited to (+/-) 2°F (adjustable). Space temperature dead band (4 °F, adjustable) is maintained during setpoint adjustments.
  3. Damper Operation:
    - a. Occupied Mode: Air flow setpoint will linearly reset based on terminal unit cooling demand as shown in the schedule below.

<b>Air Flow Setpoint-Occupied Mode</b>	
<b>Terminal Unit Cooling Demand (%)</b>	<b>Air Flow Setpoint (CFM)</b>
<b>0-100</b> (Occ sensor inactive & space temperature is within standby setpoints)	Cooling Flow Setpoint X 0.20

<b>0</b> (Occ Sensor is Active <u>or</u> Occ sensor is inactive and space temperatures are outside of the standby range)	Heating Flow Setpoint
<b>100</b> (Occ Sensor is Active <u>or</u> Occ sensor is inactive and space temperatures are outside of the standby range)	Cooling Flow Setpoint

- b. Optimal Start Mode: Air flow setpoint will reset based on the schedule below. Implement dead band to prevent oscillation between cooling and heating flow setpoints.

<b>Air Flow Setpoint – Heating Optimal Start</b>	
<b>Space Temperature &gt; Occupied Heating Set Point</b>	<b>Air Flow Set Point</b>
No	Cooling Flow Setpoint X 1.25, (Multiplier is adjustable from GUI)
Yes	Heating Flow Setpoint X 0.1, (Multiplier is adjustable from GUI)

<b>Air Flow Setpoint – Cooling Optimal Start</b>	
<b>Space Temperature &lt; Occupied Cooling Set Point</b>	<b>Air Flow Set Point</b>
No	Cooling Flow Setpoint X 1.25, (Multiplier is adjustable from GUI)
Yes	Heating Flow Setpoint X 0.1, (Multiplier is adjustable from GUI)

- c. Night High Limit, Night Purge Mode: Cooling flow setpoint shall be used during this mode. Units that did not initiate the control mode and have space temperatures above the occupied cooling setpoint shall also control to their respective cooling flow set point until the mode is canceled or the space temperature has reached the occupied cooling setpoint. Implement 1°F space temperature dead band to prevent damper oscillations.
- d. Night Low Limit Mode: Cooling flow setpoint shall be used during this mode. Units that did not initiate the control mode and have space temperatures below the occupied heating setpoint shall also control to their respective cooling flow set point until the mode is canceled or the space temperature has reached the occupied heating setpoint. Implement 1°F space temperature dead band shall be used to prevent damper oscillations.
- e. Unoccupied Mode: Damper modulates fully closed. Flow setpoint is 0 CFM.
4. Heating Valve Operation:

- a. Occupied Mode: Valve will modulate based on heating demand to maintain occupied heating setpoint.
- b. Optimal Start Mode: Heating Valve will modulate based on the schedule below. Implement 1°F space dead band to prevent valve oscillation.

Valve Position - Optimal Start	
Space Temperature > Occupied Heating Set Point	Valve Position
No	100% (Subject to discharge air temperature limiting)
Yes	0%

- c. Unoccupied Mode, Night High Limit, Night Purge Mode: Valve is closed.
- d. Night Low Limit Mode: Valve modulates fully open (Subject to discharge air temperature limiting). Units that did not initiate the control mode and have space temperatures below the occupied heating setpoint shall also modulate valves fully open until the mode is canceled or the space temperature has reached the occupied heating setpoint. Implement 1°F space temperature dead band to prevent valve oscillations.

- B. Discharge Air Temperature Limiting (All Modes):
  - 1. Discharge temperature maximum is 110° F.

- C. Space CO<sub>2</sub> Sensor:
  - 1. On Signal that space CO<sub>2</sub> values exceed set-point (1000 ppm adj.) modulate air flow damper from heating air flow to cooling air flow regardless of space demand. Disable dead band operation. Once space is below lower level set-point (800 ppm) return to normal mode. If after 30 min. (adj.) CO<sub>2</sub> level is not below lower level send signal to air handler.

**4.08 OTHER SEQUENCES**

- A. Retain existing sequences for replaced systems where no new operational changes are required.
- B. Provide DCV to all systems noted. Operate from space sensor. See article 4.06, K-8 for sequence. **Eliminate centralized CO<sub>2</sub> Control System per drawings. Add zone sequence per 4.07 C to each existing terminal device per drawings. Add sensor at air handler system and sequence to operate per 4.06-K8.**
- C. For new systems with multi-stage cooling or heating modify sequences for modulation/staging of units as required.
- D. **For new roof top package or split systems that replace package gas packs or heating and ventilation units, provide control of power exhaust fans. Fans shall modulate based on outside air damper position with a bias to maintain slight space positive pressure.**
- E. **At split system furnaces with EC motor and two stage heat add sequence and control points to:**

1. Stage fan speed from low to high based on space temperature demands. Where temperature deviates from set-point for more than 10 minutes (adj.) by more than 1.0 deg. F. increase fan speed. Otherwise operate at low speed.
  2. Stage heat to maintain space temperature and minimum discharge temperature during heating mode.
- F. At HVU-1 and 2 serving the Auxiliary Gym add control actuators to new relief dampers. Control dampers based on the position of the OSA dampers. Include an off-set to be confirmed by the balancer to control space pressure to a slight positive.
- G. At HVU-9 (East Gym Unit) and HVU-10 (West Gym Unit) serving the Main Gym add control actuators to new relief dampers. Control dampers based on the position of the OSA dampers. Include an off-set to be confirmed by the balancer to control space pressure to a slight positive.
- H. All restroom exhaust fans: Add separate schedule to operate after normal school day schedule. The intention is to allow the exhaust fans to run until 11:00 PM for custodial services. Provide on screen enable / disable function to school graphic.
- I. MAU-1: Sequence to remain as is except:
1. Install occupancy sensor in C13 team room and C16 training room. If either sensor registers an occupant and for 10 minutes following occupancy operate system in 100% OSA / 100% exhaust. Otherwise operate system as conventional heating and ventilation unit with air side economizer.
  2. Modulate RA & exhaust damper and stage exhaust fan during schedule occupancy with no room occupants. Confirm OSA damper position at which exhaust fan should operate to maintain neutral space pressure.
- J. DAH-1: Formerly MAU-2. Alter all graphics and sequences for new unit designation. Add cooling operation to sequence. See 4.06 E and F for added sequences.

**END OF SECTION 23 09 93**