



*"Your Green Heating & Cooling Professionals
Dedicated to Serving You and Your Community."*

HVAC Submittals

**Yakima Clinic
9005 SE Foster Rd.
Portland, OR 97203**

**Submitted To:
O'Neill / Walsh Community Builders
2905 SW First Ave
Portland, OR 97201**

**Submitted By:
Andersen Mechanical
16285 SW 85th Ave, Suite 410
Tigard, OR 97224**



23_05_48

Mechanical Sound and Vibration Control

STATIC DEFLECTION: --"

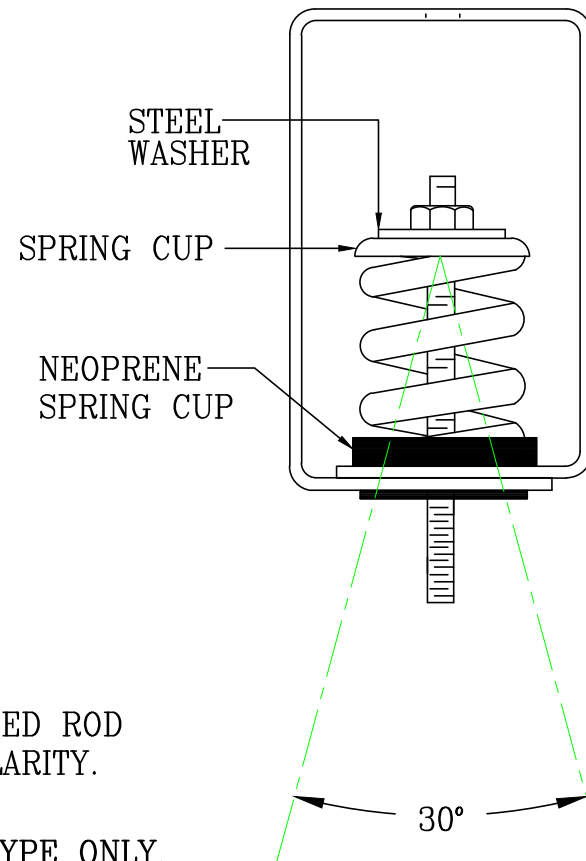
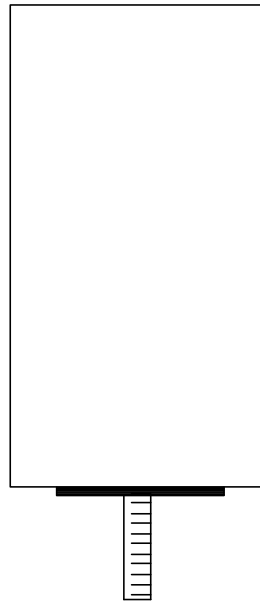

1. ALL PURPOSE SPRING HANGER WITH STABLE SPRING, THREADED ROD COUPLING, VERTICAL LIMIT STOP AND 30 DEGREE ROD ANGULARITY. FIELD ADJUSTMENT BY CONTRACTOR.
2. THIS IS A TYPICAL DRAWING SUBMITTED FOR APPROVAL OF TYPE ONLY. CERTIFIED DIMENSIONAL DRAWINGS ARE AVAILABLE, UPON REQUEST, WITH RECEIPT OF APPROVED EQUIPMENT SUBMITTALS.



TYPE : **RMXA**

M. W. SAUSSÉ & CO., INC.

28805 INDUSTRY DRIVE, VALENCIA, CA 91355
PHONE: (661) 257-3311 FAX: (661) 257-7673

STATIC DEFLECTION: --"

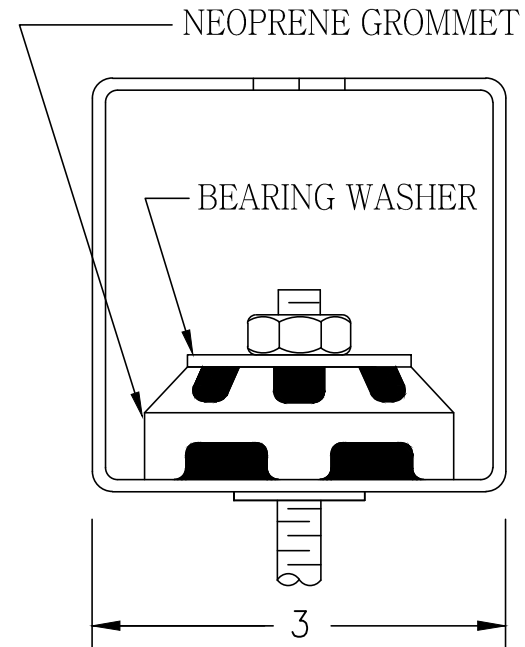
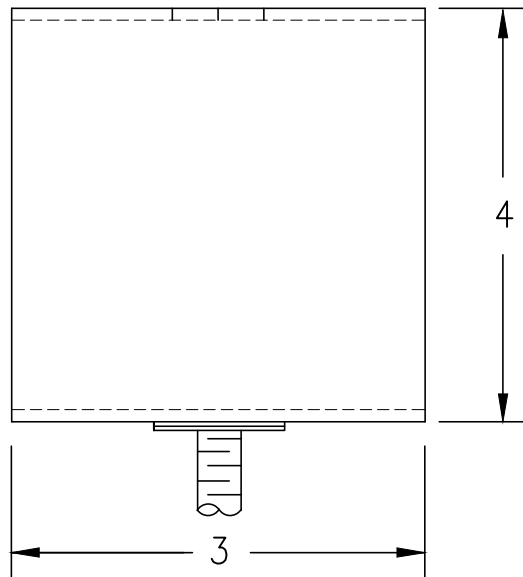

THIS IS A TYPICAL DRAWING SUBMITTED FOR APPROVAL OF TYPE ONLY.
CERTIFIED DIMENSIONAL DRAWINGS ARE AVAILABLE, UPON REQUEST, WITH
RECEIPT OF APPROVED EQUIPMENT SUBMITTALS.



TYPE : HSS

M. W. SAUSSÉ & CO., INC.

28805 INDUSTRY DRIVE, VALENCIA, CA 91355
PHONE: (661) 257-3311 FAX: (661) 257-7673