



"Your Green Heating & Cooling Professionals
Dedicated to Serving Your and Your Community"

Plumbing Submittals

**Yakima Health Clinic
9005 SE Foster Rd.
Portland, OR 97266**

**General Contractor
O'Neill / Walsh Community Builders
2905 SW First Avenue
Portland, OR 97201**

**Submitted By
Andersen Mechanical
16285 SW 85th Ave, Suite 410
Tigard, OR 97224**

*Andersen Mechanical – 16285 SW 85th Ave, Suite 410 – Tigard, OR 97224 (503)992-6664
WA License ANDERH1936QL : OR CCB 168214 : OR Plumbing License PB1464
MBE Certification #8561*



"Your Green Heating & Cooling Professionals
Dedicated to Serving Your and Your Community"

Plumbing Submittal Index

<u>22 05 00</u>	<u>Common Materials and Methods</u>
<u>22 07 00</u>	<u>Plumbing Insulation</u>
<u>22 10 00</u>	<u>Plumbing Piping and Pumps</u>
<u>22 30 00</u>	<u>Plumbing Equipment</u>
<u>22 40 00</u>	<u>Plumbing Fixtures</u>

22_07_00

Plumbing Insulation



Pipe and Equipment Insulations

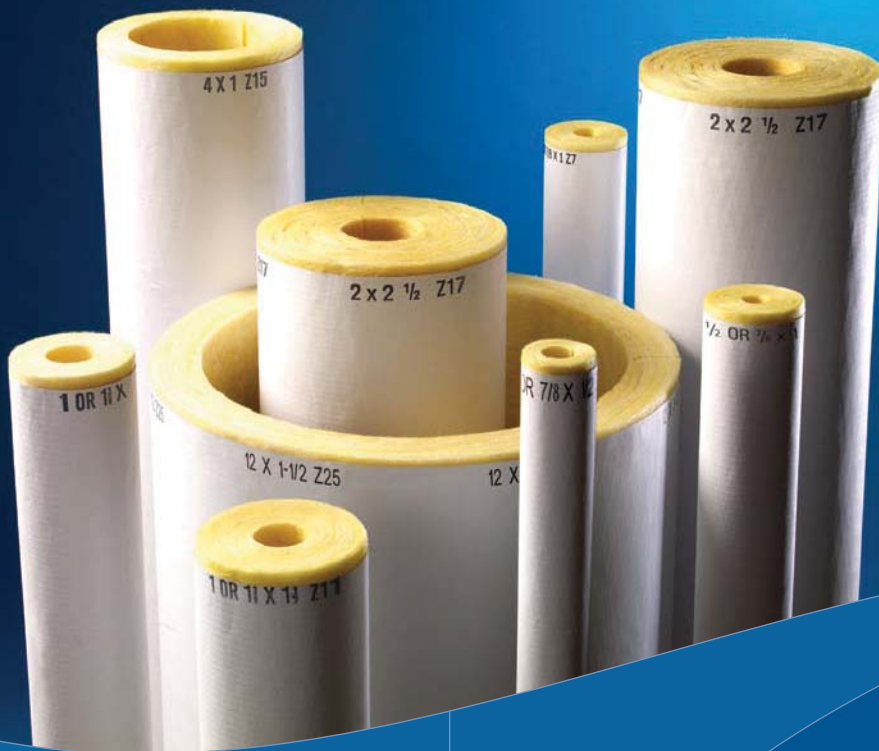

Micro-Lok[®] HP
High Performance Fiber Glass Pipe Insulation

Table of Contents

Page		Page	
2	Product Description and Benefits	8	Installation Methods
4	Application Recommendations	9	Thickness Recommendations
4	Specification Data	9	Cold Applications
5	Short Form Specification	10	Hot and Cold Applications
8	Qualifications for Use	11	Regional Sales Offices

Micro-Lok® *HP* High Performance Fiber Glass Pipe Insulation



Operating Temperature Limits: 0° to 850°F (-18° to 454°C)

Product Description and Benefits

Description

Micro-Lok *HP* high performance fiber glass pipe insulation is a rigid, one-piece insulation that offers superior insulating capabilities in applications to 850°F (454°C). It is made from rotary glass fibers bonded with a thermoset-

ting resin. The combination of these materials creates an easily installed, damage-resistant pipe insulation with high thermal efficiency, exceptional sound absorption properties and an increased operating temperature limit. This higher temperature range significantly expands the application potential for fiber glass pipe insulation.

In the manufacturing process, 3-foot (0.92 m) sections of Micro-Lok *HP* pipe insulation are cylindrically formed in one piece, then cut longitudinally through one wall and partially through the other. The result is a one-piece “hinged” construction that opens easily and closes firmly and uniformly along the entire length of the insulation. In addition to simplifying the installation process, the one-piece design used in Micro-Lok *HP* pipe insulation increases thermal effectiveness by creating only one longitudinal joint.

Micro-Lok *HP* pipe insulation is produced in 3-foot (0.92 m) sections for IPS ½" through 24" (13 mm through 610 mm), and CT sizes from ⅝" through 6⅛" (16 mm through 156 mm), depending on thickness.

Zeston® PVC fitting covers and jacketing are specifically designed for use with Micro-Lok *HP* fiber glass pipe insulation. Ideal applications for combining Zeston PVC products with Micro-Lok *HP* pipe insulation include chilled water piping, pipe systems that must meet USDA or FDA requirements, and exposed interior or exterior piping.



Jacket Types and Available Forms

ASJ SSL (All-Service Jacket with Self-Sealing Lap Closure System). The Micro-Lok *HP* fiber glass pipe insulation jacket is a high-density, white kraft bonded to an aluminum foil reinforced with fiber glass yarn. The kraft paper is chemically treated to enhance fire safety. The longitudinal lap of the jacket has a pressure-sensitive tape lap sealing system. A strong acrylic adhesive permits installation in cold weather conditions down to 15°F (-9°C) and will not soften or separate when heat and humidity are high. The adhesive is protected by a strip of easy-lift release paper with a “dry edge” to permit easy removal during installation. Matching pressure-sensitive tape butt strips, using the same adhesive and a quick release paper strip, are supplied in order to totally seal and secure the system, thus eliminating the need for staples.

Applications

Micro-Lok *HP* pipe insulation is suitable for heating applications up to 850°F (454°C) (see “Qualifications for Use”). It is designed for use on commercial, power or process lines where fire safety and a pleasing appearance are desired. Micro-Lok *HP* pipe insulation can also be used on cold and chilled water lines, brine, refrigerant and special process lines when the joints are sealed to prevent moisture migration. A weather-protective jacket is required for outdoor applications, or abuse-protective Zeston® PVC Jacketing when installed in high traffic areas or under severe conditions of temperature and high humidity.

Advantages

High Insulating Efficiency. For thermal conductivity values, refer to graph of “k” factors on page 4.

Economical to Apply. Light weight, simplicity of design and easily fabricated, one-piece construction speeds on-the-job handling and application. With the ASJ SSL jacket, the “dry edge,” easy-lift release strip makes application simple, even with gloves on.

Ready to Paint. Micro-Lok *HP* ASJ SSL jackets may be painted with a latex paint after installation.

Time and Cost Reduction. Micro-Lok *HP* pipe insulation often costs less installed than other types of insulation used in its temperature range (e.g., calcium silicate, mineral wool, or foam insulations).

Some of the advantages of Micro-Lok *HP* pipe insulation that make these cost reductions possible are:

1. One-piece construction with full-length “spring hinge” opening helps speed jobsite installation.
2. For indoor applications, a factory-applied jacket speeds installation and eliminates the need for an extra jacketing step.
3. Micro-Lok *HP* pipe insulation has a unique fiber network pattern that allows for precise and quick fabrication on the job.
4. Micro-Lok *HP* pipe insulation is light weight and easy to handle. Only three carton sizes are required to handle most pipe sizes and thicknesses.
5. The performance life of Micro-Lok *HP* pipe insulation is further enhanced by the ability of the fiber glass to resist damage from shrinking, swelling, rot and other forms of potential deterioration.

25/50 Rating. Micro-Lok *HP* fiber glass pipe insulation combined with Zeston® 2000 PVC insulated fitting covers provides a complete, integrated system with all components 25/50 rated for flame/smoke. See CI-55 product information page for additional information on Zeston 2000 PVC insulated fitting covers.



Qualifications for Use

A sufficient thickness of insulation must be used to keep the maximum surface temperature of Micro-Lok *HP* pipe insulation below 150°F (66°C). In addition, at operating temperatures above 500°F (260°C), Micro-Lok *HP* pipe insulation must be applied in a thickness ranging from 2" (51 mm) minimum to 6" (152 mm) maximum.



During initial heat-up to operating temperatures above 350°F (177°C), an acrid odor and some smoke may be given off as the organic binders used in the fiber glass pipe insulation begin to decompose. When this occurs, caution should be exercised to ventilate the area well. This loss of binder does not directly affect the thermal performance of the pipe insulation, but the compressive strength and resiliency

of the product are reduced. For applications with excessive physical abuse or vibration at high temperatures, consult the Johns Manville Regional Sales Office for alternate material recommendations.

Application Recommendations: ASJ SSL Jacket and Butt Strips

1. Do not apply Micro-Lok *HP* fiber glass pipe insulation if air temperature is below 15°F (-9°C) or above 130°F (54°C) due to the effect of temperature on tape performance. Stapling is recommended when application falls outside this temperature range.
2. If stored below 15°F (-9°C) or above 130°F (54°C), insulation cartons should stand within the recommended temperature range for 24 hours prior to application.
3. Once release paper is removed, both adhesive and lap must be kept free of dirt and water and the lap sealed immediately.
4. When adhered, the lap and butt strips must be pressurized by rubbing firmly with a plastic squeegee or the back of a knife blade to ensure positive closure.

Specification Data

Physical Properties

Service Temp. Range (ASTM C 411)	0°F to 850°F (-18°C to 454°C)
Moisture Sorption	<5% by weight
Alkalinity	<0.6% expressed as Na ₂ O
Corrosivity (ASTM C 665)	Does not accelerate
Capillarity	Negligible (after 24 hours)
Shrinkage (ASTM C 356)	None
Microbial Growth (ASTM C 1338)	Does not promote microbial growth
Surface Burning Characteristics	Composite FHC 25/50 per ASTM E 84, NFPA 255, CAN/ULC S102-M88
Limited Combustibility	NFPA 259

Jacketing

ASTM C 1136 (Type I)

Water Vapor Permeance (ASTM E 96 - Procedure A)	.02 perms max.
Burst Strength (ASTM D 774)	50 Beach Units (1.5 Joules min.)
Tensile Strength (ASTM D 828)	45 lbs./in. (7.9N/mm) width min. (MD) 30 lbs./in. (5.23N/mm) width min. (CD)

Thermal Conductivity ("k") ASTM C 335

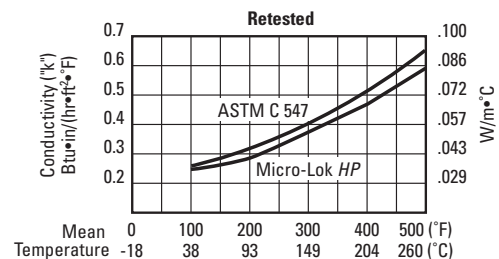

Specification Compliance

ASTM C 547 Type I (Replaces HH-I-558B, Form D, Type III, Class 12, Class 13 up to 850°F [454°C])

ASTM C 585 - Dimension Standard

ASTM C 1136 (Jacketing) (Replaces HH-B-100B, Type I & II)

MIL-I-22344D

NRC 1.36, ASTM C 795, MIL-I-24244C

USCG 164.109 - Complies; Certification Pending

New York City MEA # 330-85-M

NFPA 90A & 90B, FHC 25/50 & Limited Combustibility

Green Building Attributes

Manufacturing Location	Defiance, Ohio (43512)	
Recycled Content Pre-consumer	Pending	
Recycled Content Post-consumer	Pending	
Volatile Organic Compounds (ASTM D 5116) (Analysis ASTM D 6196 & ASTM D 5197)	Total	0.15 g/l
Fiber Glass Pipe Insulation	Formaldehyde	0.009 ppm
	Aldehydes	0.009 ppm
Volatile Organic Compounds (Calculated) Self-Sealing Lap & Butt Strips	Total	<49 g/l

Green Building Certifications

Recycled Content ES 1350 Compliance	Not Currently Available
California Title 24 Compliant	Not Certified
ENERGY STAR®	Not Currently Available
LEED Credits	Not Currently Available
LEED-NC	See JM.com/buildgreen
	JM LEED Credit Guide
	HIG-1231
EcoLogo [™] - Canadian Environmental Choice Program	N/A

ASTM Test Methods and Guidelines

C 335	Thermal Conductivity
C 356	Linear Shrinkage
C 411	Hot Surface Performance
C 547	Pipe Insulation
C 585	Simplified Dimensional Standards for Nesting (Except 3/4" [20 mm] IPS, 1" [25 mm] IPS and 1 1/8" [41 mm] CT)
C 1136	Vapor Barrier Jacketing (Type I)
C 1338	Fungi Resistance

The maximum use temperature of an insulating material is that temperature above which it no longer provides satisfactory or effective service as a thermal insulation, when applied under conditions of normal usage. A normal condition implies a nondestructive atmosphere, moderate applied loads, limited vibration and moderate thermal stresses.

No single test for determining the maximum use temperature is applicable to all types of insulation or even to any one type of insulation under all possible conditions of use.

Johns Manville uses the following ASTM Test Procedures as guidelines in the evaluation of Micro-Lok *HP* fiber glass pipe insulation and in the determination of the recommended maximum use temperature:

ASTM C 335. Thermal conductivity of pipe insulation.

ASTM C 356. Linear shrinkage of preformed, high temperature thermal insulation subjected to soaking heat. Micro-Lok *HP* pipe insulation shows negligible linear shrinkage and/or warpage after the test period, with the loss in weight not exceeding 10 percent when exposed to the test temperature.

ASTM C 411. Hot surface performance of high temperature thermal insulation. Micro-Lok *HP* fiber glass pipe insulation does not flame, glow, smolder, crack, delaminate or warp after 96-hr. exposure to the heated surface. The fiber glass pipe insulation can produce smoke and/or produce an acrid odor during initial heat-up.

The following ASTM Test Procedures are used as guidelines in the production of Micro-Lok *HP* fiber glass pipe insulation.

ASTM C 585. Inner and outer diameters of rigid thermal insulation, for nominal sizes of pipe and tubing (NPS System). Micro-Lok *HP* fiber glass pipe insulation is produced in standard sizes in order to facilitate double-layer nesting applications or retrofit at a later date. This practice provides that the inner diameter of any section of insulation is consistent with the outer diameter of pipes and tubes.

ASTM E 84. Surface Burning Characteristics of building materials. Micro-Lok *HP* fiber glass pipe insulation has a maximum flame spread rating of 25, maximum smoke developed rating of 50, representing an FHC 25/50.

ASTM C 547. Standard specification for mineral fiber, preformed pipe insulation. Type I is for use up to 850°F (454°C) with a minimum density of 3 pcf (48 kg/m³).

ASTM C 1136. Standard specification for flexible, low permeance vapor retarders for thermal insulation.

ASTM C 1338. Standard test method for determining fungi resistance of insulation materials and facings.

Short Form Specification

Scope. The work covered by this specification consists of furnishing all labor, equipment, materials and accessories and performing all operations necessary for the installation of all insulation for the plumbing, heating and air conditioning systems, in strict accordance with the insulation section of this specification and applicable drawings and subject to the terms and conditions of the contract.

All insulation should be installed by skilled workmen regularly engaged in this type of work. Insulation should be Micro-Lok *HP* fiber glass pipe insulation or products of equal performance, subject to approval prior to installation.

Surface Burning Characteristics. All insulation should have composite (insulation, jacket, tape seal and adhesive used to adhere the jacket to the insulation) Fire and Smoke Hazard ratings as tested under Procedure ASTM E 84 and NFPA 255, not exceeding:

Flame Spread.25
Smoke Developed.50

PVC fitting covers, jacketing and accessories such as adhesives, mastics, cements and cloth for fittings should have the same component ratings as listed above.

Paper laminate jackets should be permanently flame and smoke resistant. Chemicals used for treating paper in jacket laminates should not be water soluble and should be unaffected by water and humidity.

Insulation should be applied on clean, dry surfaces and only after tests and approvals required by the specifications have been completed.

All pipe insulation should be continuous through wall and ceiling openings and sleeves, except where fire stop materials are required.

Insulation on all cold surfaces must be applied with a continuous, unbroken vapor seal. Hangers, supports, anchors, etc., that are secured directly to cold surfaces must be adequately insulated and vapor sealed to prevent condensation. Under severe conditions of physical abuse or high humidity, additional protection is required.

All surface finishes are to be extended to protect all surfaces, ends and raw edges of insulation.

Rigid insulation inserts should be installed on pipe sizes 1½" (38 mm) or larger under outside hangers. Inserts should be of equal thickness to the adjoining insulation and should be provided with vapor retarder seals where required.

Insulation inserts should not be less than the following lengths:

Pipe Size		Length	
in.	mm	in.	mm
1½ – 2½	40 – 65	10	254
3 – 6	80 – 150	12	305
8 – 10	200 – 250	16	406
12 & up	300 & up	22	559

Galvanized metal shields should be applied between hangers or supports and the pipe insulation. Shields should be formed to fit the insulation and should extend up to the centerline of the pipe and the length specified for the insulation hanger inserts less 4" (102 mm) to allow for vapor retarding butt joints on each side of shields.

Specified adhesives, mastics and coatings should be applied at the manufacturer's recommended minimum coverage per gallon.

All Indoor Piping Systems Operating Up to 850°F (454°C)

Piping Exposed and Concealed Micro-Lok *HP* ASJ SSL (aluminized foil-scrim-kraft laminate and pressure-sensitive tape).

Insulation should be applied over clean, dry pipe with all joints butted firmly together. Longitudinal jacket laps and butt strips should be smoothly secured according to manufacturer's recommendations.

**Application Recommendations:
ASJ SSL Jacket & Butt Strips**

1. Do not apply Micro-Lok *HP* fiber glass pipe insulation if air temperature is below 15°F (-9°C) or above 130°F (54°C), due to the effect of temperature on tape performance. We recommend stapling when application falls outside this temperature range.
2. If stored below 15°F (-9°C) or above 130°F (54°C), insulation cartons should stand within the recommended temperature range for 24 hours prior to application.
3. Once release paper is removed, both adhesive and lap must be kept free of dirt and water and the lap sealed immediately.
4. When adhered, the lap and butt strips must be pressurized by rubbing firmly with a plastic squeegee or the back of a knife blade to ensure positive closure.

Note to the Specifier. Delete sections not used; fill in correct selections where indicated and/or add other information as required. Insulation thickness or thermal resistances are not indicated; they should be derived from the designer's own calculations and/or from sources such as:

ASHRAE Std. 90.1-2004 "Energy Efficient Design of New Buildings Except New Low-Rise Residential Buildings"

NAIMA Economic Insulation Thickness Guidelines for Piping and Equipment

NAIMA 3E Plus® Insulation Thickness Computer Program

Refer to product information pages for physical and thermal properties and compliance with standards and specifications.

Fittings

Fittings, valves and flanges should be insulated with Zeston 2000 PVC insulated fitting covers and Hi-Lo® Temp insulation inserts.

Hot Systems

Fittings should be insulated by applying the proper factory precut Hi-Lo Temp insulation insert to the pipe fitting. The ends of the Hi-Lo Temp insulation insert should be tucked snugly into the throat of the fitting and the edges adjacent to the pipe covering tufted and tucked in, fully insulating the pipe fitting. The Zeston 2000 PVC fitting cover is then applied and should be secured by tack fastening, banding or taping the ends to the adjacent pipe covering.

On fittings where the operating temperature exceeds 250°F (121°C), two or more layers of the Hi-Lo Temp insulation inserts should be applied prior to the installation of the Zeston 2000 PVC fitting cover in order to limit the temperature to less than or equal to 150°F (66°C). The first layer should be applied with a few wrappings of fiber glass yarn to eliminate voids or hot spots.

Cold Systems

Fittings should be insulated by applying the proper factory precut Hi-Lo Temp insulation insert to the pipe fitting. The ends of the Hi-Lo Temp insulation insert should be tucked snugly into the throat of the fitting and the edges adjacent to the pipe covering tufted and tucked in, fully insulating the pipe fitting.

A vapor retarder mastic compatible with the Zeston 2000 PVC should be applied around the edges of the adjoining pipe insulation and on the fitting cover throat overlap seam. The Zeston 2000 PVC fitting cover is then applied and should be secured with pressure-sensitive white Z-Tape along the circumferential edges. The tape should extend over the adjacent pipe insulation and have an overlap on itself at least 2" (51 mm) on the downward side.

On fittings where the operating temperature is below 45°F (7°C), two or more layers of the Hi-Lo Temp insulation inserts should be applied with the first layer being secured with a few wrappings of fiber glass yarn.

Refrigerant Systems and Cold Systems in Severe Ambient Conditions

Fittings should be insulated to a full thickness as the adjacent pipe insulation, with either Hi-Lo inserts or segmented pipe insulation which has been mitered to conform to the Zeston 2000 PVC fitting cover. An intermediate vapor retarder compatible with the Zeston 2000 PVC should be applied, completely sealing the insulation prior to installing the Zeston 2000 PVC fitting cover. A vapor retarder mastic should then be applied around the edges of the adjoining pipe insulation and on the fitting cover overlap seam. The Zeston 2000 PVC fitting cover is then applied and should be secured with pressure-sensitive white Z-Tape along the throat seam and the circumferential edges overlapping itself 2" (51 mm) on the downward side.

Note: For more detailed, illustrated installation instructions for the various systems, please refer to CI-35.

Outdoor Piping Systems Operating Up to 850°F (454°C)

Piping and Fittings. Micro-Lok *HP* plain pipe insulation should be wired or taped in place over clean, dry pipe with all joints butted firmly together. If a vapor retarder is required, Micro-Lok *HP* fiber glass pipe insulation should be used.

The insulation should be finished with metal jacketing with a laminated moisture retarder or Zeston 2000 PVC in 20 or 30 mil (0.5 or 0.8 mm) thickness. Metal jacketing should be overlapped 2" to 3" (51 mm to 76 mm) and held in place with metal bands. Zeston 2000 PVC jacketing should be secured by overlapping and sealing all joints with Zeston Perma-Weld® solvent welding adhesive. (Refer to CI-35 for detailed installation instructions for Zeston 2000 PVC jacketing and fitting covers.) Elbows and tees for metal-jacketed systems should be finished with matching metal fitting covers. Other fittings in metal-jacketed systems should be finished with conventional weather-resistant insulating materials with painted aluminum finish.

Qualifications for Use

Fitting Insulation. When the pipe insulation thickness is greater than 1½" (38 mm) or the pipe temperature is greater than 250°F (121°C) or less than 45°F (7°C), additional insulation inserts should be used. A rule of a thumb for these conditions is to use one Hi-Lo Temp insert for each additional 1" (25 mm) of pipe insulation.

Fitting Cover. The temperature of the Zeston 2000 PVC fitting cover must be kept below 150°F (66°C) by the use of a proper thickness of insulation and by keeping the PVC cover away from contact with, or exposure to, sources of direct or radiant heat.

Installation Methods

ASJ SSL Jacket

Seal circumferential joints with supplied butt strips.

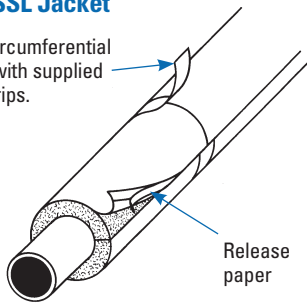

Ring Hangers*

*Not recommended for cold or high temperature pipes.

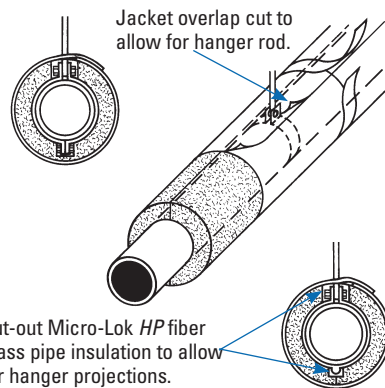

Field-Applied Metal Jacket

Overlap jacket sufficiently to provide weather resistance.

Aluminum jacket with laminated moisture retarder.

Secure Micro-Lok HP fiber glass pipe insulation with wire or band.

Secure metal with metal bands at butt joint overlaps and between joints.

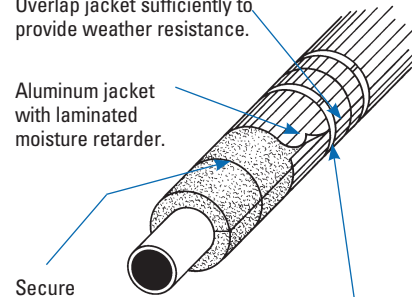

Pipe Shoe on Roller Support

ASJ SSL or metal jacket outdoors.

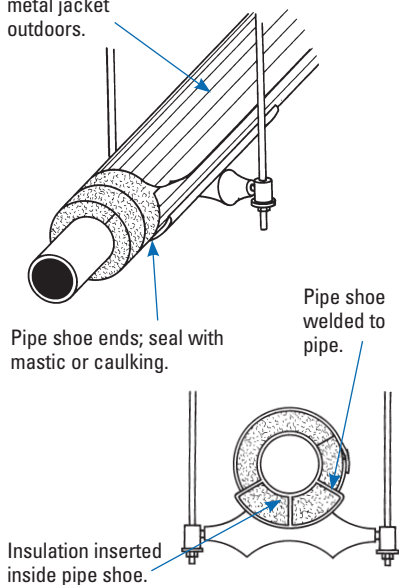

Clevis Hanger

ASJ SSL jacket or metal jacket (cold pipes require ASJ SSL jacket under metal jacket).

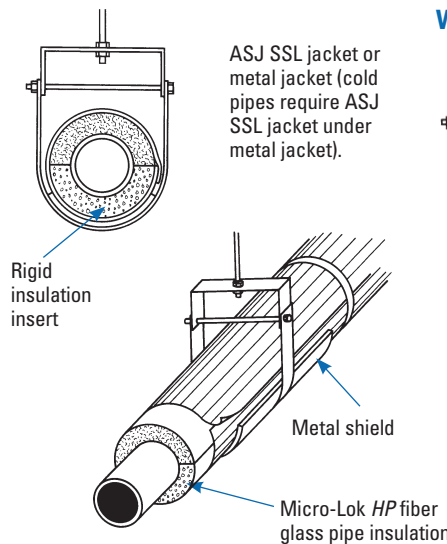

Wooden Block

(Not recommended for temperatures over 450°F [232°C]).

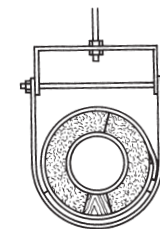

Thickness Recommendations

Cold Applications Condensation Control

Minimum Insulation Thickness to Prevent Condensation

(Based on still air and ASJ SSL Jacket)

Operating Pipe Temp. (°F)	80°F & 90% RH		80°F & 70% RH		80°F & 50% RH	
	Pipe Size (in)	Thick. (in)	Pipe Size (in)	Thick. (in)	Pipe Size (in)	Thick. (in)
0 - 34	Up to 1	2	Up to 8 10 to 30	1 1½	Up to 8 10 to 30	1 1
	1¼ to 2	2½				
	2½ to 8	3				
	10 to 30	3½				
35 - 49	Up to 1½	1½	Up to 4 4½ to 30	1 1	Up to 30	1
	2 to 8	2				
	10 to 30	2½				
50 - 70	Up to 3	1½	Up to 30	½	Up to 30	½
	3½ to 20	1½				
	24 to 30	1½				

Operating Pipe Temp. (°C)	27°C & 90% RH		27°C & 70% RH		27°C & 50% RH	
	Pipe Size (mm)	Thick. (mm)	Pipe Size (mm)	Thick. (mm)	Pipe Size (mm)	Thick. (mm)
-18 to 1	Up to 25	51	Up to 200 250 to 750	25 38	Up to 200 250 to 750	25 25
	32 to 50	64				
	65 to 200	76				
	250 to 750	89				
2-9	Up to 40	38	Up to 100 115 to 750	25 25	Up to 750	25
	50 to 200	51				
	250 to 750	64				
10-21	Up to 80	38	Up to 750	13	Up to 750	13
	90 to 500	38				
	600 to 750	38				

Hot and Cold Applications ASHRAE Std. 90.1-1989

Minimum Pipe Insulation

Fluid Design Operating Temperature Range	Insulation Conductivity		Nominal Pipe Diameter					
	Conductivity Range	Mean Rating Temperature	Run Outs ^a					
			up to 2"	1" and less	1½" to 2"	2½" to 4"	5" & 6"	8" & up
Heating Systems (Steam, Steam Condensate and Hot Water)								
(°F)	Btu•in/(hr•ft ² •°F)	(°F)	(in)	(in)	(in)	(in)	(in)	(in)
Above 350	0.32 - 0.34	250	1.5	2.5	2.5	3.0	3.5	3.5
251 - 350	0.29 - 0.31	200	1.5	2.0	2.5	2.5	3.5	3.5
201 - 250	0.27 - 0.30	150	1.0	1.5	1.5	2.0	2.0	3.5
141 - 200	0.25 - 0.29	125	0.5	1.5	1.5	1.5	1.5	1.5
105 - 140	0.24 - 0.28	100	0.5	1.0	1.0	1.0	1.5	1.5
Domestic and Service Hot Water Systems^b								
105 and Greater	0.24 - 0.28	100	0.5	1.0	1.0	1.5	1.5	1.5
Cooling Systems (Chilled Water, Brine and Refrigerant)^c								
40 - 55	0.23 - 0.27	75	0.5	0.5	0.75	1.0	1.0	1.0
Below 40	0.23 - 0.27	75	1.0	1.0	1.5	1.5	1.5	1.5

^a Runouts to individual terminal units not exceeding 12 ft. (3.66 m) in length.

^b Applies to recirculating sections of service or domestic hot water systems and first 8 ft. (2.44 m) from storage tank for non-recirculating systems.

^c The required minimum thicknesses do not consider water vapor transmission and condensation. Additional insulation, vapor retarders, or both, may be required to limit water vapor transmission and condensation.

Hot and Cold Applications ASHRAE Std. 90.1-2004

Minimum Pipe Insulation

Fluid Design Operating Temperature Range	Insulation Conductivity		Nominal Pipe Diameter				
	Conductivity Range*	Mean Rating Temperature	Less than 1"	1" to less than 1½"	1½" to less than 4"	4" to less than 8"	8" & up
Heating Systems (Steam, Steam Condensate and Hot Water)^{†**}							
(°F)	Btu•in/(hr•ft ² •°F)	(°F)	(in)	(in)	(in)	(in)	(in)
Above 350	0.32 - 0.34	250	2.5	3.0	3.0	4.0	4.0
251 - 350	0.29 - 0.32	200	1.5	2.5	3.0	3.0	3.0
201 - 250	0.27 - 0.30	150	1.5	1.5	2.0	2.0	2.0
141 - 200	0.25 - 0.29	125	1.0	1.0	1.0	1.5	1.5
105 - 140	0.22 - 0.28	100	0.5	0.5	1.0	1.0	1.0
Domestic and Service Hot Water Systems							
105 and Greater	0.22 - 0.28	100	0.5	0.5	1.0	1.0	1.0
Cooling Systems (Chilled Water, Brine and Refrigerant)^{††}							
40 - 60	0.22 - 0.28	100	0.5	0.5	1.0	1.0	1.0
Below 40	0.22 - 0.28	100	0.5	1.0	1.0	1.0	1.5

* For insulation outside the stated conductivity range, the minimum thickness (T) should be determined as follows:

$$T = r \{ (1 + t/r)^{K/k} - 1 \}$$

where T = minimum insulation thickness (in.), r = actual outside radius of pipe (in.), t = insulation thickness listed in this table for applicable fluid temperature and pipe size, K = conductivity of alternate material at mean rating temperature indicated for the applicable fluid temperature (Btu•in/(hr•ft²•°F)); and k = the upper value of the conductivity range listed in this table for the applicable fluid temperature.

† These thicknesses are based on energy efficiency considerations only. Additional insulation is sometimes required relative to safety issues/surface temperature.

** Piping insulation is not required between the control valve and coil on run outs when the control valve is located within 4 ft. (1.22 m) of the coil and the pipe size is 1 in. (25 mm) or less.

†† These thicknesses are based on energy efficiency considerations only. Issues such as water vapor permeability or surface condensation sometimes require vapor retarders or additional insulation.

Please consult your local Building Code to determine which version compliance is required.



Product Information

For additional information on Johns Manville's complete line of Pipe and Equipment Insulations, request the following product data sheets by the form numbers listed below.

Pipe and Equipment Insulations	Product Data Sheet Form Number
Micro-Lok® <i>HP</i> High Performance Fiber Glass Pipe Insulation	CI-228
Zeston® 2000 PVC Insulated Fitting Covers and Jacketing	CI-55, CI-26
Zeston® 300 Series PVC Fitting Covers and Jacketing	CI-67, CI-26
800 Series Spin-Glas® Duct and Equipment Insulation	CI-9
1000 Series Spin-Glas®	CI-60-A
Precipitator Spin-Glas®	CI-60-B
HTB 26 Spin-Glas®	CI-60-C
Micro-Flex™ Large Diameter Pipe and Tank Wrap	CI-187
Incombustible Hullboard	CI-85
Incombustible Microlite®	CI-151
Microlite® XG™ Formaldehyde-free™ Fiber Glass Duct Wrap Insulation	AHS-331

Micro-Lok® *HP*, Zeston®, Spin-Glas® and Microlite® are registered trademarks of Johns Manville.

North American Sales Offices, Insulation Systems

Eastern Region

P.O. Box 158
Defiance, OH 43512
(800) 334-2399
Fax: (419) 784-7866

Western Region & Canada

P.O. Box 5108
Denver, CO 80217
(800) 368-4431
Fax: (303) 978-4661

The physical and chemical properties of Micro-Lok® *HP* High Performance Fiber Glass Pipe Insulation listed herein represent typical, average values obtained in accordance with accepted test methods and are subject to normal manufacturing variations. They are supplied as a technical service and are subject to change without notice. Numerical flame spread and smoke developed ratings are not intended to reflect hazards presented by these or any other materials under actual fire conditions. Check with the Regional Sales Office nearest you to assure current information. **All Johns Manville products are sold subject to Johns Manville's standard Terms and Conditions including Limited Warranty and Limitation of Remedy. For a copy of the Johns Manville standard Terms and Conditions, Limited Warranty and Limitation of Remedy, and information on other Johns Manville thermal insulations and systems, call (800) 654-3103.**



717 17th St.
Denver, CO 80202
(800) 654-3103
specJM.com

CI-245 3-08 (New)

 Printed on recycled paper.

Copyright ©2008 Johns Manville
Printed in USA

Features

- Protect insulated or bare pipes
- Meets most requirements for federal, state and local fire-safety codes
- Accepted for commercial, institutional, industrial and residential projects in all parts of the US
- System is uncomplicated and easy to install
- UV-resistant for outdoor applications
- Long-lasting protection and an attractive finished appearance
- Available with Hi-Lo Temp fiber glass inserts

Applications

- Commercial, institutional and industrial applications

Construction

- Covering and jacketing manufactured from high-impact, gloss white, UV-resistant polyvinyl chloride jacketing

Application Recommendations

- Wrap the Hi-Lo Temp fiber glass insert completely around the pipe fitting without overly compressing it or leaving any voids
- Ensure that the insulation insert covers all exposed surfaces
- Install the Zeston PVC fitting cover over the pipe fitting and fiber glass insert by securing the throat of the Zeston PVC insert using either serrated tacks, Perma-Weld adhesive or Zeston Z-Tape
- If applied in an outdoor setting or exposed to the sun, precautions should be taken to account for expansion joints



**ZESTON 2000 SERIES WHITE PVC
INSULATED FITTING COVERS AND JACKETING**

QUALIFICATIONS FOR USE

Hot Systems

- Use proper insulation thickness to ensure PVC covers are kept below 150°F (66°C)
- PVC covers should be kept away from contact with and/or exposure to sources of direct or radiated heat
- For fittings where operating temperatures exceed 250°F (121°C) or where pipe insulation thickness is greater than 1½" (38mm), two or more layers of Hi-Lo Temp insulation inserts are required beneath the fitting cover (refer to MECH-261 Zeston Hi-Lo Temp Inserts)

Cold Systems

- An approved vapor-barrier compatible with PVC must be applied between pipe insulation and fitting cover and on fitting cover throat overlap seal. Please refer to Insulspec MECH-261 on jm.com
- For fittings where operating temperature is below 45°F (7°C) or where the pipe insulation thickness is greater than 1½" (38mm), two or more layers of Hi-Lo Temp insulation inserts are required beneath fitting cover (refer to MECH-261 Zeston Hi-Lo Temp Inserts)

Refrigerant Systems and Cold Systems In Severe Ambient Conditioning

- Mitered pipe insulation segments, fabricated or pre-molded insulation shapes may be used in lieu of Hi-Lo temp insulation inserts
- An intermediate vapor-barrier compatible with PVC is required to completely seal the insulation prior to installing the Zeston 2000 PVC fitting cover
- Care should be taken to ensure the vapor barrier mastic is applied between the pipe insulation and the fitting cover and on the fitting cover throat overlap seam

Totally Sealed Systems (USDA Approval)

- 20 or 30 mil (0.5 mm or 0.8mm) Zeston PVC jacketing should be applied to pipe insulation in conjunction with Zeston PVC fitting covers
- Circumferential and longitudinal jacket and fitting cover seams should be sealed with Zeston Perma-Weld solvent welding adhesive
- Circumferential seams should be a minimum of 1" (25mm) overlap and longitudinal seams should be 1½" - 2" (38mm to 51mm) overlap
- Upon completion, all seams should visually be checked for seal and, if necessary, touched up
- Slip joints are periodically required between fixed supports and on continuous long runs of straight piping.
- To implement a slip joint, increase the circumferential overlap to 8" to 10" (203 mm to 254 mm) and apply a flexible white caulking in the overlap area to maintain a sealed system
- Refer to Zeston installation instructions CI-35 at www.jm.com

PERFORMANCE SPECIFICATIONS

Electrical Conductance	Non-conductor
Elongation at Yield (MD), %	3.0
Flame Spread	25 or less (up to 30 mil [0.8mm])
Flexural Modulus, psi (kPa)	430,000 (2,964,750)
Flexural Strength, psi (kPa)	11,000 (75,850)
	10 mil (0.3 mm) 1.3
	15 mil (0.4 mm) 1.4
	20 mil (0.5 mm) 1.5
	30 mil (0.8 mm) 1.6
Gardner – SPI Impact, in.lb./mil by Ductile Failure	50 or less (up to 30 mil [0.8 mm])
Smoke Developed	1.48
Specific Gravity	425,000 (2,930,270)
Tensile Modulus, psi (kPa)	6,000 (41,370)
Tensile Strength at Yield, psi (kPa)	

SPECIFICATION COMPLIANCE

ASTM	D257 (Electrical surface resistance)
	D638 (Tensile strength)
	D790 (Flexural Strength)
	D792 (Density & specific gravity)
	D1784 (Specification for rigid PVC)
	D3679 (Specification for rigid PVC)
	E84 (Surface burning characteristics)
	E136 25/50 non-combustibility (fiber glass inserts)
Agriculture Canada	Pass (Canada Department of Agriculture)
Canada	CGSB51-GP-53M
CAN/ULC	S102
L-P*: Composition	535E (Federal standard for PVC)
A, Type II, Grade GU	1035A (US Army standard PVC)
New York City MEA	#7-87 (Toxicity test)
USDA	US Department of Agriculture

COMPRESSED THERMAL CONDUCTIVITY ZESTON HI-LO TEMP INSULATION INSERTS

Mean Temperature		"K"	
°F	°C	BTU•in/(hr•ft ² •°F)	W/M•°C
75	24	0.23	0.033
150	66	0.27	0.039
300	149	0.40	0.058

FOR ADDITIONAL INFORMATION CONSULT THE FULL PRODUCT MANUAL.

The physical and chemical properties of PRODUCT listed herein represent typical, average values obtained in accordance with accepted test methods and are subject to normal manufacturing variations. They are supplied as technical service and are subject to change without notice. Numerical flame spread and smoke developed ratings are not intended to reflect hazards presented by these or any other materials under actual fire conditions. Check with the Regional Sales Office nearest you to assure current information. All Johns Manville products are sold subject to Johns Manville's standard Terms and Conditions including Limited Warranty and Limitation of Remedy. For a copy of the Johns Manville standard Terms and Conditions, Limited warranty and Limitation of Remedy, and information on other Johns Manville thermal insulations and systems, call (800)-654-3103 Limited Warranty and Limitation of Remedy. For a copy of the Johns Manville standard Terms and Conditions, Limited Warranty and Limitation of Remedy, and information on other Johns Manville thermal insulations and systems, call (800) 654-3103.